

# Analog electronic TE/LE drivers

integral-to-valve format, for proportional valves with one or two spool position transducers

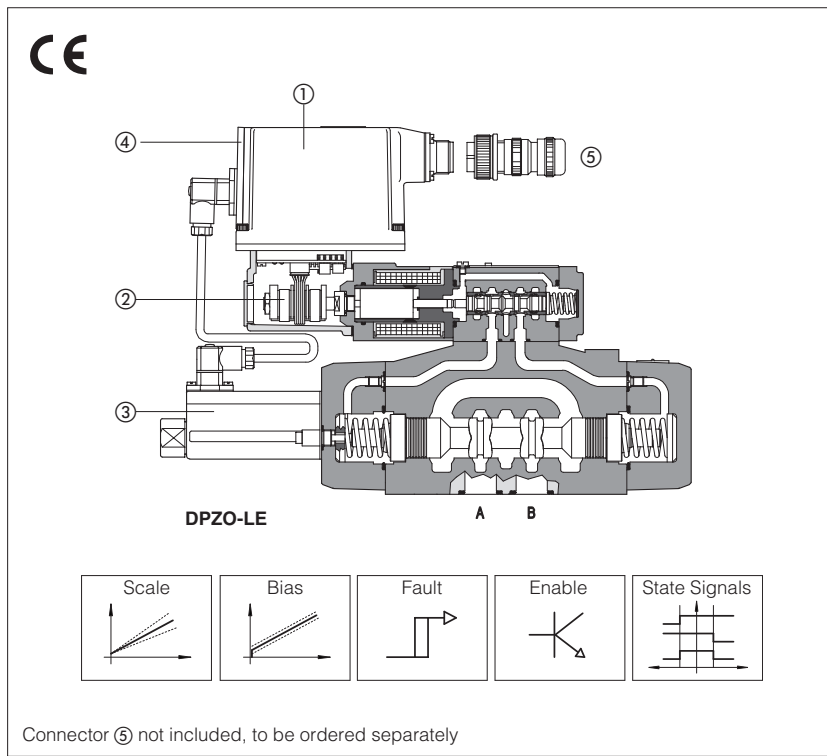

## TE/LE

Analog integral drivers ① supply and control, in closed loop, the position of the spool or poppet of direct and pilot operated proportional valves according to the electronic reference input signal.

TE execution operates direct and pilot operated directional/flow control valves with one integral spool position transducer ②.

LE execution operates directional pilot operated valves with two integral spool position transducer ② and ③.

### Features:

- Integral-to-valve analog electronic, factory preset for best performances
- Potentiometer adjustment ④ of bias and scale
- Standard 7 pin main connector ⑤ for power supply, analog input reference and monitor signals
- /Z option 12 pin main connector for additional enable and fault signals
- IP67 protection degree
- CE mark according to EMC directive

## 1 VALVES RANGE

Valves model	Directional			Cartridge	Flow	Directional	Cartridge	
	DHZO DKZOR	DPZO	DLHZO DLKZOR	LIQZO	QVHZO QVKZOR	DPZO	LIQZO	LIQZO
Data sheet	F165	F172	F180	F320	F412	F175	F330	F340
Driver model	TE					LE		

## 2 MAIN CHARACTERISTICS

Power supply	Nominal: +24 Vdc    Rectified and filtered: $V_{RMS} = 21 \div 32 V_{MAX}$ (ripple max 10 % VPP)
Max power consumption	50 W
Reference input signal	Input impedance: voltage $R_i > 50 \text{ k}\Omega$ (range $\pm 10 \text{ Vdc}$ ) current $R_i = 316 \Omega$ (range $4 \div 20 \text{ mA}$ )
Monitor output	Output range : voltage $\pm 10 \text{ Vdc}$ @ max 5 mA current $4 \div 20 \text{ mA}$ @ max 500 $\Omega$ load resistance
Enable input	Input impedance: $R_i > 10 \text{ k}\Omega$ ; range: $0 \div 5 \text{ Vdc}$ (OFF state), $9 \div 24 \text{ Vdc}$ (ON state), $5 \div 9 \text{ Vdc}$ (not accepted)
Fault output	Output range : $0 \div 24 \text{ Vdc}$ ( ON state $> [\text{power supply} - 2 \text{ V}]$ ; OFF state $< 1 \text{ V}$ ) @ max 50 mA; external negative voltage not allowed (e.g. due to inductive loads)
Alarms	Cable break with current reference signal and valve spool trasducer cable break
Format	Sealed box on the valve; IP67 protection degree
Operating temperature	$-20 \div +60 \text{ }^\circ\text{C}$ (storage $-20 \div +70 \text{ }^\circ\text{C}$ )
Mass	Approx. 445 g
Additional characteristics	Short circuit protection of solenoid's current supply; spool position control by P.I.D. with rapid solenoid switching
Electromagnetic compatibility (EMC)	According to Directive 2004/108/CE (Immunity: EN 50082-2; Emission: EN 50081-2)
Calibrations	Remove the rear cover to access bias and scale regulations
Recommended wiring cable (see 7)	LiYCY shielded cables

**Note:** a minimum time of 20 ms to 120 ms have be considered between the driver energizing with the 24 Vdc power supply and when the valve is ready to operate. During this time the current to the valve coils is switched to zero

### 3 CONNECTIONS, SETTINGS AND LED

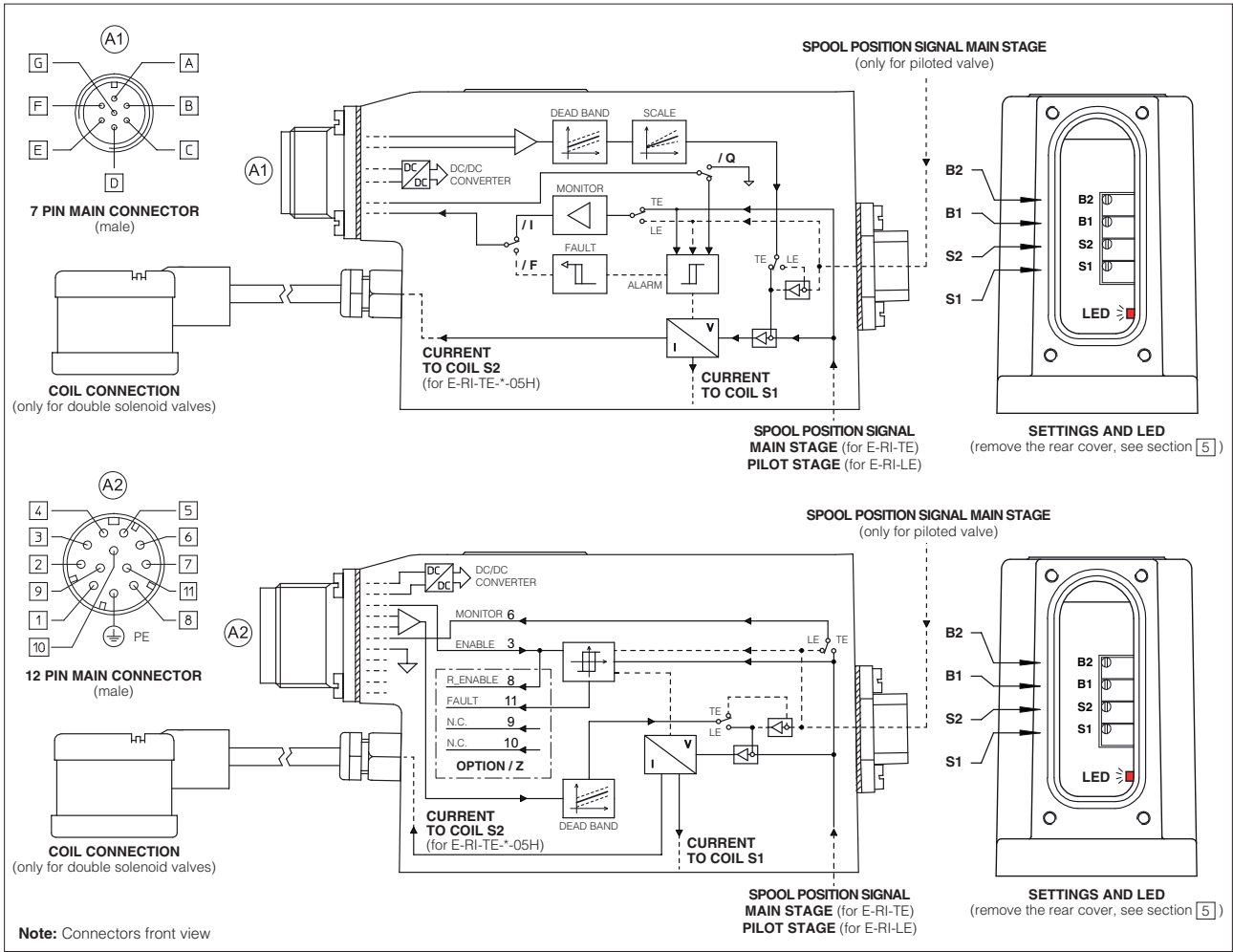

#### 3.1 Main connector - 7 pin - standard, /Q and /F options (A1)

PIN	SIGNAL	TECHNICAL SPECIFICATIONS	NOTES
A	<b>V+</b>	Power supply 24 Vdc for solenoid power stage and driver logic	Input - power supply
B	<b>V0</b>	Power supply 0 Vdc for solenoid power stage and driver logic	Gnd - power supply
C	<b>AGND</b>	Ground - signal zero for MONITOR signal	Gnd - analog signal
	<b>ENABLE</b>	Enable (24 Vdc) or disable (0 Vdc) the driver (for /Q option) with /Q option ENABLE signal replaces AGND on pin C; MONITOR signal is referred to pin B	Input - on/off signal
D	<b>INPUT+</b>	Reference analog differential input: $\pm 10$ Vdc maximum range (4 $\div$ 20 mA for /I option)	Input - analog signal
E	<b>INPUT -</b>	For single solenoid valves the reference input is 0 $\div$ +10 Vdc (4 $\div$ 20 mA for /I option) For double solenoid valves the reference input is $\pm 10$ Vdc (4 $\div$ 20 mA for /I option)	
F	<b>MONITOR</b>	Monitor analog output: $\pm 10$ Vdc maximum range (4 $\div$ 20 mA for /I option)	Output - analog signal
	<b>FAULT</b>	Fault (0 Vdc) or normal working (for /F option) with /F option FAULT signal replaces MONITOR on pin F	Output - on/off signal
G	<b>EARTH</b>	Internally connected to the driver housing	

#### 3.2 Main connector - 12 pin - /Z option (A2)

PIN	SIGNAL	TECHNICAL SPECIFICATIONS	NOTES
1	<b>V+</b>	Power supply 24 Vdc for solenoid power stage and driver logic	Input - power supply
2	<b>V0</b>	Power supply 0 Vdc for solenoid power stage and driver logic	Gnd - power supply
3	<b>ENABLE</b>	Enable (24 Vdc) or disable (0 Vdc) the driver	Input - on/off signal
4	<b>INPUT+</b>	Reference analog differential input: $\pm 10$ Vdc maximum range (4 $\div$ 20 mA for /I option)	Input - analog signal
5	<b>INPUT -</b>	For single solenoid valves the reference input is 0 $\div$ +10 Vdc (4 $\div$ 20 mA for /I option) For double solenoid valves the reference input is $\pm 10$ Vdc (4 $\div$ 20 mA for /I option)	
6	<b>MONITOR</b>	Monitor analog output: $\pm 10$ Vdc maximum range (4 $\div$ 20 mA for /I option)	Output - analog signal
7	<b>AGND</b>	Ground - signal zero for MONITOR signal	Gnd - analog signal
8	<b>R_ENABLE</b>	Repeat Enable - output repetition of Enable input	Output - on/off signal
9	<b>NC</b>	Do not connect	Output - on/off signal
10	<b>NC</b>	Do not connect	Output - on/off signal
11	<b>FAULT</b>	Fault (0 Vdc) or normal working (24 Vdc)	Output - on/off signal
PE	<b>EARTH</b>	Internally connected to the driver housing	

## 4 OPTIONS

Standard driver execution provides on the 7 pin main connector:

- Power supply** - 24Vdc must be appropriately stabilized or rectified and filtered; a 2,5 A safety fuse is required in series to the driver power supply. Apply at least a 10000  $\mu$ F/40 V capacitance to single phase rectifiers or a 4700  $\mu$ F/40 V capacitance to three phase rectifiers
- Reference input signal** - analog differential input with  $\pm 10$  Vdc nominal range (pin D,E), proportional to desired valve spool position
- Monitor output signal** - analog output signal proportional to the actual valve's spool position with  $\pm 10$  Vdc nominal range

Atos drivers are CE marked according to the applicable directives (e.g. Immunity/Emission EMC Directive).

Installation, wirings and start-up procedures must be performed according to the general prescriptions shown in tech table **F003**.

The electrical signals of the valve (e.g. monitor signals) must not be directly used to activate safety functions, like to switch-ON/OFF the machine's safety components, as prescribed by the European standards (Safety requirements of fluid technology systems and components-hydraulics, EN-982).

Following options are available to adapt standard execution to special application requirements:

### 4.1 Option /F

It provides a Fault output signal in place of the Monitor output signal, to indicate fault conditions of the driver (cable interruption of spool transducers or reference signal - for /I option): Fault presence corresponds to 0 Vdc, normal working corresponds to 24 Vdc.

### 4.2 Option /I

It provides the 4 $\pm$ 20 mA current reference and monitor signals instead of the standard  $\pm 10$  Vdc.

It is normally used in case of long distance between the machine control unit and the valve or whenever the reference signal can be affected by electrical noise; the valve functioning is disabled in case of reference signal cable breakage.

### 4.3 Option /Q

It provides the possibility to enable or disable the valve functioning without cutting the power supply (the valve functioning is disabled but the driver current output stage is still active). To enable the driver, supply a 24 Vdc on the enable input signal.

### 4.4 Option /Z

This option includes /F and /Q features, plus the Monitor output signal.

When the driver is disabled (0 Vdc on enable signal) fault output is forced to 0 Vdc.

### 4.5 Possible combined options: /FI and /IZ

## 5 SETTINGS AND LED

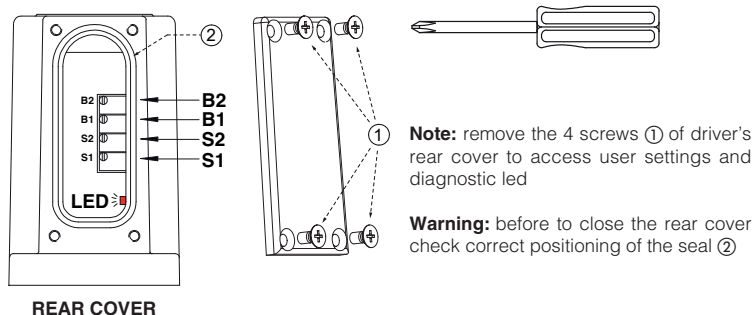

### LED

Diagnostic led shows the presence of driver's fault conditions (e.g. spool transducers cable breakage or reference signal cable breakage for /I option):

- Normal working = LED turned off
- Fault presence = LED turned on

Single solenoid directional control valve, two positions with positive overlapping

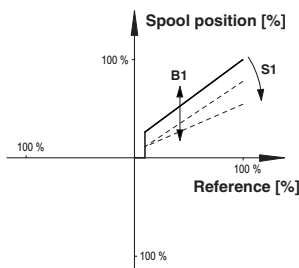

**B1** bias adjust  
**S1** scale adjust

Threshold = 2%  
(200mV or 0,32mA for /I option)

Double solenoid directional control valve, three position with positive overlapping

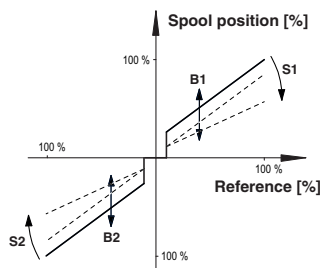

**B1** positive bias adjust  
**S1** positive scale adjust  
**B2** negative bias adjust  
**S2** negative scale adjust

Threshold = 2%  
( $\pm 200$ mV or  $\pm 0,16$ mA for /I option)

Single or double solenoid directional control valve, three position with zero overlapping

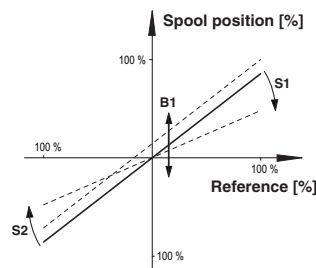

**B1** bias adjust (offset)  
**S1** positive scale adjust  
**S2** negative scale adjust

**6 OVERALL DIMENSIONS [mm]**

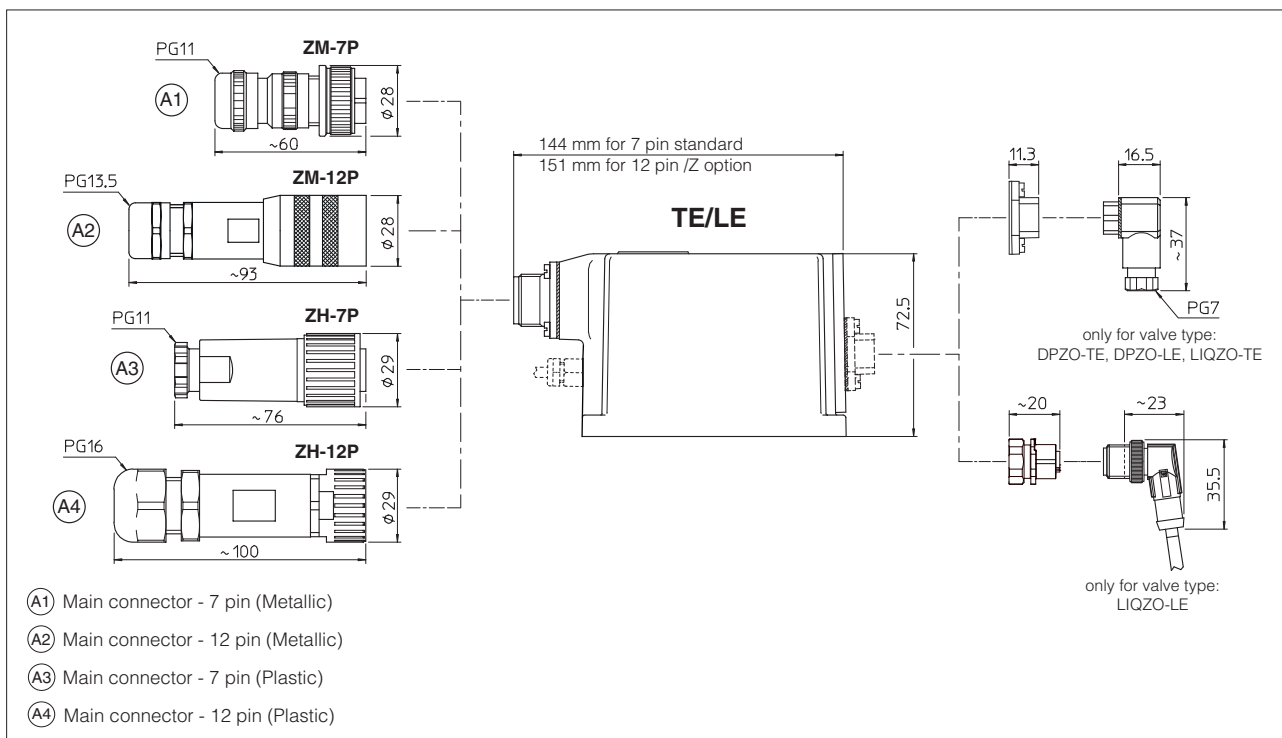

**7 CONNECTORS CHARACTERISTICS** - to be ordered separately

**7.1 Main connectors - 7 pin**

CONNECTOR TYPE	POWER SUPPLY	POWER SUPPLY
CODE	(A1) <b>ZM-7P</b>	(A3) <b>ZH-7P</b>
Type	7pin female straight circular	7pin female straight circular
Standard	According to MIL-C-5015	According to MIL-C-5015
Material	Metallic	Plastic reinforced with fiber glass
Cable gland	PG11	PG11
Cable	LiYCY 7 x 0,75 mm <sup>2</sup> max 20 m (logic and power supply) LiYCY 7 x 1 mm <sup>2</sup> max 40 m (logic and power supply)	LiYCY 7 x 0,75 mm <sup>2</sup> max 20 m (logic and power supply) LiYCY 7 x 1 mm <sup>2</sup> max 40 m (logic and power supply)
Connection type	to solder	to solder
Protection (EN 60529)	IP 67	IP 67

**7.2 Main connectors - 12 pin**

CONNECTOR TYPE	POWER SUPPLY	POWER SUPPLY
CODE	(A2) <b>ZM-12P</b>	(A4) <b>ZH-12P</b>
Type	12pin female straight circular	12pin female straight circular
Standard	DIN 43651	DIN 43651
Material	Metallic	Plastic reinforced with fiber glass
Cable gland	PG13,5	PG16
Cable	LiYCY 12 x 0,75 mm <sup>2</sup> max 20 m (logic and power supply)	LiYCY 10 x 0,14mm <sup>2</sup> max 40 m (logic) LiYY 3 x 1mm <sup>2</sup> max 40 m (power supply)
Connection type	to crimp	to crimp
Protection (EN 60529)	IP 67	IP 67

**8 MODEL CODE FOR SPARE PARTS**

Integral drivers are available as spare parts only for Atos authorized service centers.

<p><b>E-RI</b></p> <p>Integral electronic driver</p>	-	<p><b>TE</b></p> <p>TE = for proportional valves with one position transducer LE = for proportional valves with two position transducers</p>	-	<p><b>01H</b></p> <p>01H = for single solenoid proportional valves 05H = for double solenoid proportional valves (only for -TE)</p>	/	<p><b>*</b></p>	/	<p><b>*</b></p> <p>Set code (1)</p> <p>Series number</p>
--	---	--	---	---	---	-----------------	---	--

**Options, see section 4 :**

- = standard voltage reference input ( $\pm 10$  VDC)
- I = current reference input and monitor (4 ÷ 20 mA)
- F = fault signal
- Q = enable signal
- Z = with enable, fault and monitor (12 pin connector)

(1) set code identifies the correspondance between the integral driver and the relevant valve; it is assigned by Atos when the driver is ordered as spare part